



REAR TRACTOR MOWER

FPM 804 162

Ident: 19907 - radni zahvat 1,2 m

Ident: 39477 - radni zahvat 1,6 m

KOSAČICA SE AGREGATIRA NA MALE TRAKTORE KOJI IMAJU SISTEM VEŠANJA U TRI TAČKE PREMA ISO 730/II, i IZLAZNI BROJ OBRTAJA 540 min⁻¹

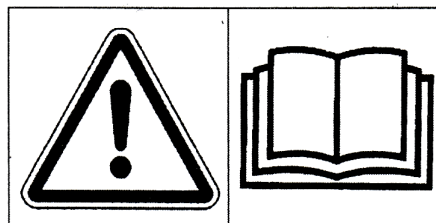
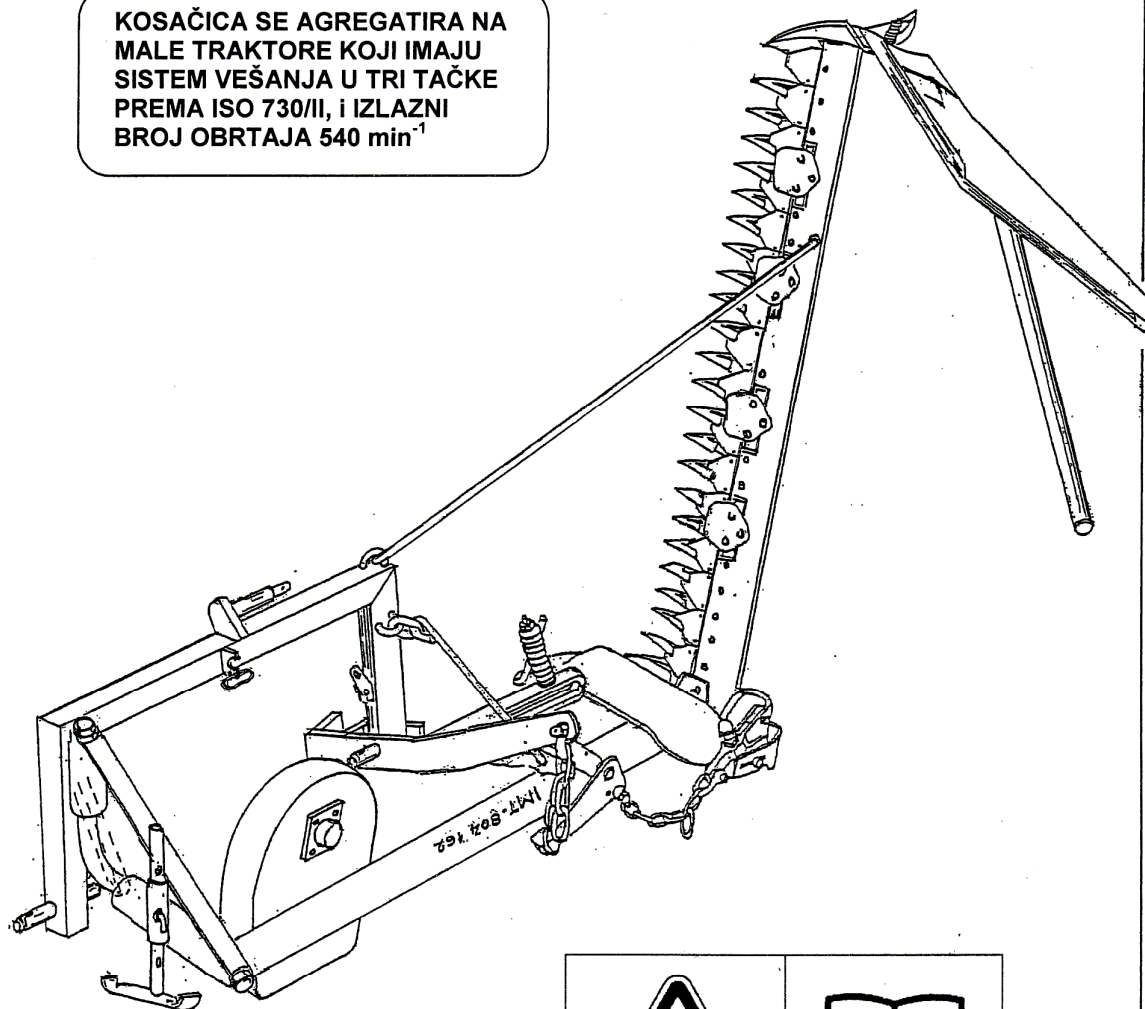

№ 21962

INSTALLATION/HANDLING/MAINTENANCE 01.2011.

The mower is aggregated to small tractors that have a three-point hanging system acc.to ISO 730/II and number of output rotations 540min⁻¹

Ident:19907 working grasp 1.2m

Ident:39477 working grasp 1.6m

WARNING FOR YOU, USER

By purchasing this machine, you made a wise choice. It is the result of many years of contemplation, research and development. You, like thousands of other users, will realize that you own the best that the technique, knowledge and testing in the field has created. You bought a reliable machine, but only if you use it properly, you can expect a good performance and a long service life.

This manual gives you all the information you need to achieve the best possible efficiency with your machine. This effect largely depends on how well you read and understand this manual and apply this knowledge. It's a simple machine, but often you can overcome the defects that are obvious and prove to be bad work, which is often due to neglecting the natural wear of parts or the fact that the machine is not well tuned. Therefore, do not pretend to know how the machine is used and maintained before you read this manual, which you need to keep at hand.

Our service dealers and sales service centers with their trained staff can offer you all the original parts of tractor mowers for servicing. These parts are manufactured and carefully inspected in the same factory where the mower is made, in order to ensure high quality and precise assembly at each replacement.

REAR TRACTOR MOWER IS PRODUCED BY: FPM AGROMEHANIKA DOO BOLJEVAC

The rear tractor mower meets the criteria prescribed by the Rules on the Safety of Machines ("Official Gazette of the Republic of Serbia", No. 13/2010), especially regarding the stability and protection of parts and assemblies that could endanger the safety of the operator by their function and shape.

TRAINING: FPM Agromehanika DOO constantly strives to improve its products and therefore reserves the right to make changes or improvements when needed, without any obligation to modify or supplement previously manufactured or sold equipment.

The information in this manual is correct at the date of issue.

All rights to the press and images retained by:
FPM AGROMEHANIKA DOO BOLJEVAC

**THE CERTIFICATE ON OCCUPATIONAL SAFETY MEASURES IS A CONSTITUENT OF
THE INSTRUCTIONS FOR HANDLING AND MAINTENANCE**



Issued by: FPM Agromehanika DOO Boljevac
Print: DEVELOPMENT SERVICE IMT AGROMEHANIKA AD BOLJEVAC
Year: 01.2011

INSTRUCTIONS
FOR HANDLING AND
MAINTENANCE
OF REAR TRACTOR MOWER
FPM 804 162

- **Postoje dva radna zahvata ove kose:**

Ident: 19907 – work grasp 1.2 m

Ident: 39477 – work grasp 1.6 m

- **The mower is aggregated on small tractors with
three-point suspension system according to ISO 730
/ I and output speed $n = 540 \text{ min}^{-1}$**



CONTENT

№ 21962

PAGE	TABULAR OVERVIEW
	GROUP OF PARTS
5	Safety warning
6	Limited warranty
7	Introduction
7	caution
8	Instructions for safe work
8	Description of rear tractor mower
9 - 10	Aggregating the mower to a tractor
11 - 12	Adjusting the mower for work
12 - 13	Working with the mower
13	Maintenance of the mower
14 - 15	Adjusting the gap on the cutting machine
15	Sharpening and replacing the blades on the movable cutting strip
16	Technical characteristics
17	Certificate - Occupational safety measures were applied

WARNING FOR YOU, USER

It is very important that the cardan shaft you attach to your rear tractor mower is of the prescribed dimensions. Therefore, it is necessary to obtain a cardan shaft of the following characteristics:

- wrinkle 35 JUS M.L1.601 on both ends of the universal shaft
- continuous torque $M_r = 160 \text{ Nm}$
- max. angle of rotation of the joint at work $\alpha = 30^\circ$
- For $\alpha > 30^\circ$, turn the cardan shaft off
- after every 8 hours of operation, apply lubrication

The cardan shaft is the product of the company "FKL" Temerin, and can be purchased under the number:

05B - 570 - 10.10 - 10.10



IMPORTANT: If you do not comply with the warning, the factory will not be liable for damages or fractures on the tractor, cardan shaft or rear tractor mower.

READ CAREFULLY!

In this manual and on the machine you will find warning labels, "WARNING" "CAUTION" and "DANGER". Warnings aim to draw attention to the personal caution and caution of those who work with you because they also need to read it.

PERSONAL SAFETY

WARNING: The word "WARNING" is used where you need to be careful to protect the operator and other persons from an accident.

CAUTION: The word "CAUTION" indicates the possibility of serious injury to the operator and personnel that may occur suddenly. It is a commonly used word as a warning to the operator and other people to prevent surprises in using the mower.

DANGER: The word "DANGER" denotes what can not be done because it entails a risk.

THERE ARE ADDITIONAL WARNINGS SUCH AS "RECOMMENDED" AND "IMPORTANT", DENOTING SPECIAL INSTRUCTIONS WITH REGARD TO THE SAFETY OF THE REAR TRACTOR MOWER.

SAFETY OF THE REAR TRACTOR MOWER

NOTE: THIS WARNING DENOTES THE POSSIBILITY OF DAMAGE TO MOWER, IF YOU DO NOT COMPLY WITH THE INSTRUCTIONS.

IMPORTANT: THE READER IS INFORMED ON WHAT THEY SHOULD KNOW TO PREVENT MALFUNCION OF THE MOWER, IN CASE THEY MISS IT.

WARNING!

IF YOU DO NOT COMPLY WITH THE "WARNING", "CAUTION" AND "DANGER", SERIOUS INJURIES MIGHT OCCUR.

LIMITED WARRANTY

The factory provides a warranty in accordance with the Law on Standardization, the Rulebook on the Safety of Machines ("Official Gazette of the Republic of Serbia", No. 13/2010) for each original piece of a new mower delivered to the user by the sales network FPM Agromehanika AD Boljevac, which guarantees at the time of delivery, that every part of the mower is new, free of material defects, and that the rear tractor mower is given a warranty for a period of one year from the date of delivery to the user, provided that the machine is used and serviced in accordance with the recommendations in this INSTRUCTION MANUAL for maintenance and handling.

EXCEPTIONS:

1. Parts made of wood are not covered by the warranty.
2. Parts not manufactured by FPM Agromehanika AD Boljevac (tires, plastics, belts, cardan shafts, cardan shields, hydraulic cylinders with connection hoses, etc.) are not covered by this warranty, but by the manufacturer's warranty
3. Parts that are normally consumed in exploitation, such as: wedge belts, discs, cutting blades, tires, scrapers, cutter blades, sliders underneath the cutting machine, protective guard.
4. This warranty is not valid in case of poor use, improper or negligent use or damage due to an accident. The warranty ceases to be valid due to the use of non-original parts, and the factory is not responsible for the damage resulting from the transport.

THE FACTORY IS NOT RESPONSIBLE FOR LOSS OF THE PROFIT DUE TO MALFUNCTION OF THE MOWER OR THE FAILURE OF THIRD PARTIES, NOR FOR ADDITIONAL COSTS OF WORK ON REMOVAL AND REPLACEMENT OF PARTS.

The buyer is responsible and bear the costs of the following:

1. Normal maintenance, such as lubrication, oil retention, minor adjustments, and the like.
2. Transport of the mower where the service is performed in the warranty period and return.
3. Time of travel of the authorized service to the owner of the mower and return, or delivery and return of the mower from the workshop after the repair.

This warranty does not apply to the rear tractor mower which has been modified without our explicit permission, or if it was performed by someone else, outside the authorized service.

The warranty is related to strict adherence to the warning:

- all the instructions in this manual must be respected and all shields are regularly reviewed and replaced,
as needed.

No warranty is given for products that are not new.

The people who just work in our factory are not officially representatives of the factory and do not have the right to assume any obligation on its behalf.

No warranty covers product equipment that is larger than that given, so the factory is not responsible for any injuries caused by such use.

INTRODUCTION

The rear tractor mower FPM 804 162 belongs to the group of modern tools from our production program and is intended for cutting all kinds of fodder plants. According to its construction, it is located in the group of worn rear mowers and it has the possibility of aggregating to small tractors that have a three-point attachment system and a six-gang type output shaft, 34.9 mm in diameter. According to its constructive and exploitative characteristics, the rear tractor mower is a very high quality and reliable product with the following characteristics:

- Simple and strong construction,
- Great work performance,
- Easy and quick aggregation and unloading from the tractor,
- Fast switch from transport to working position,
- Minimum maintenance,
- Existence of a safety system for disconnecting the cutting device at a hook on an obstacle,
- Low energy consumption,
- Easy handling and adjustment.

The mower is delivered in the form of sub-assemblies that are very easily interconnected. In addition to the mower, a cardan shaft is also delivered, the length of which is adjusted depending on the type of tractor and according to the instructions on the protective coating.

Good knowledge and practical application of the instructions for working with the rear tractor mower allows you to be reliable in operation, and its lifetime is long. Please note that during the term of the warranty period you should not disassemble certain parts of the mower, because in this case, the warranty is lost. Also, the factory does not take any responsibility if on some parts of the rear tractor mower during the warranty period are damaged due to improper handling and maintenance.

Servicing measures, other than lubrication and easy maintenance, which can be easily carried out, should be left to our service representatives or service centers that have trained staff.

To maintain and repair the rear tractor mower, use the original parts that can be obtained from authorized service agents or directly at the factory.

CAUTION

The operating instructions correspond to the basic model of the rear tractor mower FPM 804 162. Since your mower can fit a part that functionally fits the explanation while the shape is slightly different, please do not pay attention to such things.

The identification of the rear tractor mower is done via the nameplate. The table contains the following information:

– In the field with the letter "Z" - the number of certificates of occupational safety is entered.

– In the "MASA / WEIGHT" field - the weight of the product is entered.

– In the "GODINA / YEAR" field - the year of production (last two digits).

– In the "SERIJA / TYPE" field - the series label and the commercial mark of the product.

– In the field "No." the number of tractor mowers composed of nine digits is entered and has the following meaning.

- first digit - year of production

- second and third digit - code of the manufacturer

- the other six digits - serial number

of the product from the start of production.



SAFETY INSTRUCTIONS



Before proceeding with any work with the rear tractor mower, carefully read the INSTRUCTIONS and remember the following:

- The user of the rear tractor mower is responsible for the safety of people and animals that are found

in the area of use, so make sure that the other person is not nearby when working. One should always think of the consequences of irresponsible work because they are irreparable.

- On sloping terrains, make sure that there is no slipping and overturning with a mower, rain or moisture accelerates the sliding of the tractor, as well as the accumulation of mud on double fingers on the cutting so avoid working in a humid terrain.
- All cleaning and maintenance work on the rear tractor must only be carried out when the tractor is stopped and the drive shaft is deactivated.
- Check the lubrication as well as other sliding surfaces.
- Check the degree of damage to the cutting edges of the blade and, if necessary, sharpen the blades in order to maintain proper cutting.
- Where there is a likelihood of a hidden obstacle working with more attention and slower speed.
- In order to avoid the drift of the rear tractor mower, both in work and in transport, it is mandatory to use tractor stabilizers, or chains that are accompanying tractor equipment.
- When working on the drive mechanism of the mower, a protective sheet metal must be used.
- In order to ensure safe operation with the mower, follow the instructions given in this manual.

DESCRIPTION OF THE REAR TRACTOR MOWER

The rear tractor mower consists of:

- Bearing constructions with transmission,
- Cutter.

The supporting structure consists of:

- Connecting part,
- Cutter carrier.

The supporting structure is constructively resolved so that, in addition to its basic purpose - the function of attachment to the tractor and carrying the transmission with the cutting machine, it also has the task to enable the cutting apparatus to better copy the terrain with the help of the system of swivel joints and levers.

Also within the supporting structure there is a safety system which, in the event of an impact of the cutting device in a hidden obstacle, makes it unroll and turn, thereby protecting it from damage.

The system for transferring movement from the output shaft of the tractor to the movable cutting bar consists of: a cardan shaft, a gearbox with wedge belts and a flywheel with an eccentrically mounted sleeve and crank levers.

The cardan shaft is connected at one end with the drive shaft of the belt drive and the other is connected to the output shaft of the tractor. The transmission gear consists of a drive and driven pulley connected with two v-belts. The crochet lever at one end is connected to the flywheel and the other end is connected to the movable cutting lath.

AGGREGATING THE MOWER TO A TRACTOR

Before starting the mower attachment to the tractor, it is necessary to connect the independently delivered assemblies.

- With the cutting machine, release the shaft and the wooden grass guide



- Unscrew the M12x30 screw on the rear of the cutter blade (Fig. 1, Item 1) and then remove the slider located below the bend.
- Remove the splinters (fig. 1, item 2) provided by the shafts (figure 1, items 3 and 4) for the connection of the cutting device and the supporting structure, and then remove the shafts from the eyelets.
- Lubricate the fuselage and holes on the eyelets with multi-purpose lubricant.
- Insert the blades of the cutting device (fig. 1, item 5) into the eyelets on the couch, and then insert the shafts (fig. 1, items 3 and 4) into the holes on the eyelets and resistors (Figure 1, Item 2) lift the cutting machine, place the slider on the hub and then secure it with the previously removed M12x30 screw.
- Connect the chainsaw for holding the cutting apparatus (fig. 1, item 6) using a tweezer (fig. 1, item 7) with a tension on the cutting machine (fig. 1, item 8).
- Connect the crank lever (fig. 1, item 9) to the ball of the movable battens (fig. 1, item 10). Fasten the joint with a screw, a roller nut and a fork (fig. 1, item 11).
- Insert multi-purpose lubricant before installing the joint in the lever with a cup.



WARNING:

The joint must be properly attached, otherwise it will be bumped during operation and the ball and lever with a cup will be damaged.

- On the shaft (fig. 2, item 1), fix the wooden guide of the grass (fig. 2, item 2).
- Connect the spool (fig. 2, item 1) using the screw (fig. 2, items 3,4 and 5) to connect the springs and nuts with the beak (fig. 2, item 6) on the cutting machine.

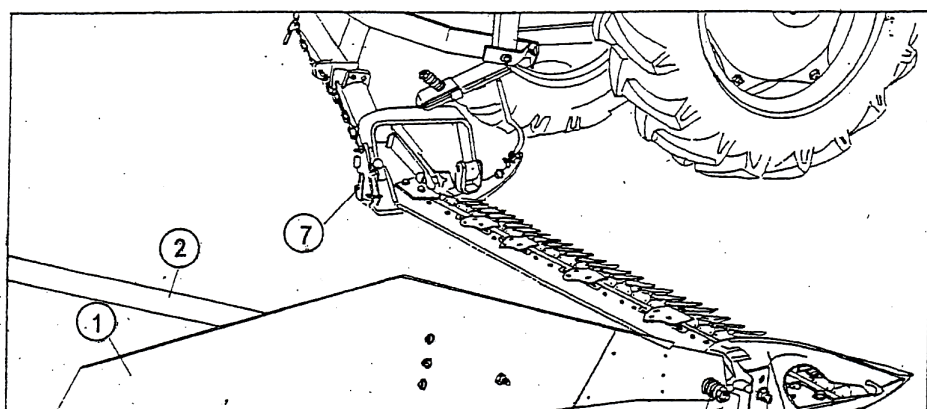

- To facilitate the attachment to the tractor, remove the footrest and position it so that the bearing - the rack is lifted as far as the connecting points reach the height of the lowered tractor levers (Fig. 3, see broken lines).
- Move the tractor backwards and pull the connecting sleeves on the bearing of the mower (Fig. 3, items 4 and 5) into the joints on the tractor levers, and then extend the upper tractor lever - warning (fig. 3, item 1) to lock the shaft (Fig. 3, Item 2) and fuse (fig. 3, pos.3) on the mower's frame.

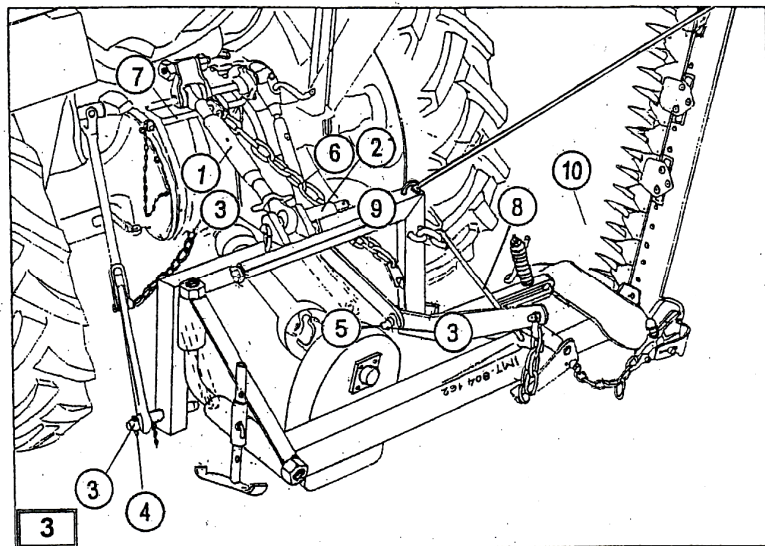

- Connect the cardan shaft to the output shaft of the tractor. Connection is carried out in such a way that the finger presses the fuse and the cardan shaft attachment is attached to the output shaft of the tractor, after which the fuse is released by lifting the finger and thus the attachment fork is secured from the draw.
- Ensure that the cardan shaft is secured by tying the chain to the upper tractor lever - warning.

ADJUSTING THE MOWER FOR WORK

In order to ensure the correct operation of the mower, it is necessary to make the necessary adjustments before starting work. A flat surface should be selected for adjustment.

- Release the mower restraint for the transport position (Fig. 3, Item 8) and attach it to the eyelet located on the mower's frame.
- Unscrew the handle of the mower holder in the vertical and remove it (fig. 3, item 10).
- The whole mower is lowered by hydraulics until the bowl firmly rests on the ground, then the hydraulics chains (figure 3, item 6) are fastened to the required length - approximately tightened.
- Use the hydraulics to raise the mower so that the slider (fig. 4, item 6) is 8 to 10 cm from the ground and use the flat object of the approximate height (Fig. 4, Item 1).
- Use the hydraulics to lower the mower so that the slider rests on the padded object.

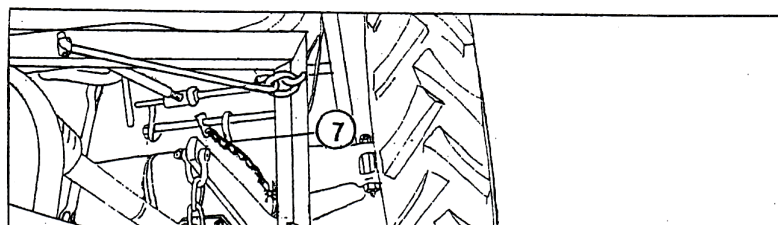

- Use the chain (fig. 4, item 2) and the tension chain (figure 4, item 3) to adjust the mower so that the beak of the mower (Figure 2, Item 6) touches the ground.
- For fine adjustment of the cutting machine, use a screw with a counter nut (fig. 4, item 5).
- Adjustment of the safety system for swinging in the event of an obstacle encounter, is carried out by tightening or unscrewing the nut (fig. 5, item 4) on the spindle carrying the spring (fig. 5, item 5) of the safety system.
- The pre-setting which is correctly performed allows the cutting machine to monitor the terrain correctly during operation.
- The cut off angle is selected depending on the state of the grass to mow.
- The cut on the ground fodder should be as normal as possible to the tree.
- Setting the angle of cut of the stem is done by means of warming (figure 5, item 6).
- Adjusting the cut height is done with sliders underneath the canopy (Figure 2, Item 7) and below the beak (Figure 2, Item 8). The sliders must be fixed with the existing screws on the mower and beak after adjustment.

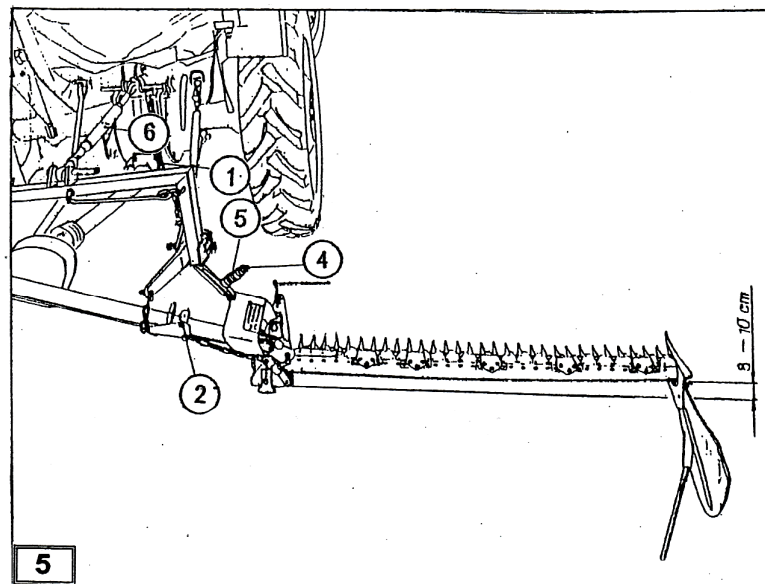

- Cutting height - mowing is very important because it leaves traces not only for the next mowing but also for the other agrotechnic that is being carried out. Three types of cuts are applied: the lowest 3 - 4 cm for the mowing of meadows in mountainous areas, medium 5 - 6 cm for mowing mixtures for silage and the cultures that go in silage.
- Place the wooden lawnmower on the shovel (fig. 2, item 2) in the position that suits most.

BEFORE YOU START WORK, YOU NEED TO:

- Remove the protector on the cutting machine,
- Check the tightness of all bolts,
- Lubricate all oilers,
- Lubricate the joint that connects the crank lever and the movable cutting lath.

Lubrication is carried out with multi-purpose lubricant.

WORKING WITH THE MOWER

Before starting mowing, it is necessary to examine the parcel, and if there are some obstacles to remove them.

The speed of mowing moves in the range of 4 - 8 km / h, depending on the terrain and condition of the mow.

According to the state of the cultivated mowing, as well as the condition of the soil, the cutting height is adjusted.

During mowing, the conditions under which the mower will mow should be considered. If you notice the obstacles they should be removed and continue to mow. The mowing should be carried out with full working of the mower, in order for it to be fully economically justified.

For cutting grass, there is a movable cutting sling with smooth knives and for cutting dry grass and cereals with toothed knives.

If during operation, the cutting machine hits a hidden obstacle, the safety device will cut off the mower, and in order to continue mowing it is necessary to stop the tractor and turn off the output shaft, and then return the tractor slightly backwards and lift the mower hydraulically. By lifting the cutting machine, the safety system is returned to the working position.

If during normal operation, the system is unlocked, it is necessary to tighten the spring.

If the slipping wedge is stuck, the tractor should be stopped, then the mower must be turned off, the tractor moved backward, and then the tailgate must be identified as a cause of jamming. Check the tension of the straps before starting work again.

When finished, prepare the mower for transport.

- Through the double fingers on the cutting machine, set the protector,
- Place the cutting machine in a vertical position and secure it with the holder and the handle that has a nut on it.
- Depress the cutting device from the ground and secure with the handle for the transport position (fig. 3, item 8)
- Use the hydraulics to lift the mower in the upper position, and then make the chain shortening (figure 3, item 6) to the required transport length, thus releasing the tractor hydraulic system.

MAINTENANCE OF THE MOWER

The mower should be neatly lubricated and properly adjusted. Lubrication of the mower should be a constant practice, as this will prolong its lifetime. Before starting the work, it is necessary to lubricate all lubrication points, the nozzle, which connects the movable lath with the crank lever and other sliding joints.

For lubrication, use multi-purpose lubricant. A spherical ball sphere has a slit that serves to bring lubricant to the joint.

Checking the belt tension and tightening them is done as follows:

- Remove three M8x25 screws securing the belt guard and then remove the guard.
- Press the straps with your hand and check how far they are. The correct belt loosening is 10 mm (see Figure 6).

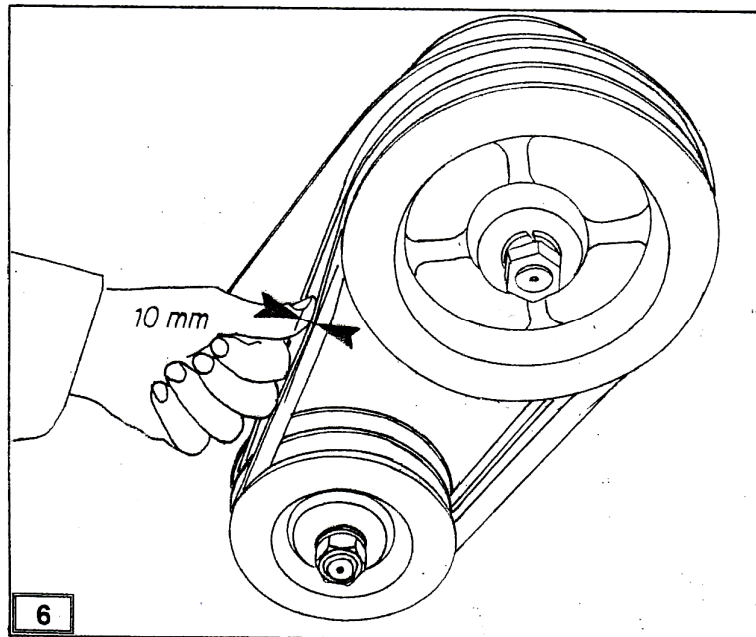

NOTE:

- When replacing worn-out belts, replace both straps regardless of the state of one against the other.
- After completion of the previous operations, install the belt guard.

Adjusting the gap on the cutting machine

After a longer period of use, the quality of mowing decreases due to the wear of the cutting machine guide. Carefully clean the cutting machine and then slip the sliding joints, so that the cutting blade can be easily started. Adjusting the gap between the guides is performed as follows:

- Check for proper clearance between the movable knife and the fixed knife on the double finger (see fig. 7, items 1 and 2).
- If the clearance does not exist beneath the inner guides (figure 8, item 4), insert the adjusting pads (fig. 8, item 6). When inserting the pads it is necessary to unscrew the screw (fig. 8, item 5) and remove the outer and inner guide (Fig. 8, item 3 and 4) and then return the inner guide.

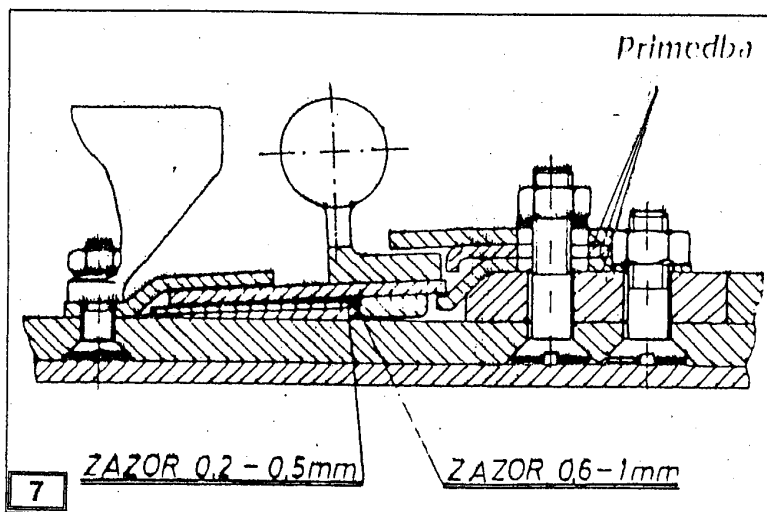

Slika 7

- When the pre-setting is completed, return the outer guide and screw in place. Do not tighten the screw to the end.
- Release the "counter" nut (Fig. 8, Item 8) and then screw or unscrew the screw (fig. 8, item 7) with the hexagon wrench until the correct guide of the outer guide on the slider of the slat.
- After finishing the setting, tighten the screw (fig. 8, item 5) and the "counter" nut (Fig. 8, poz. 8). Tighten the "counter" of the nut with a fork key at the same time preventing the screw unwinding (figure 8, item 7) using the "hexagonal" wrench.

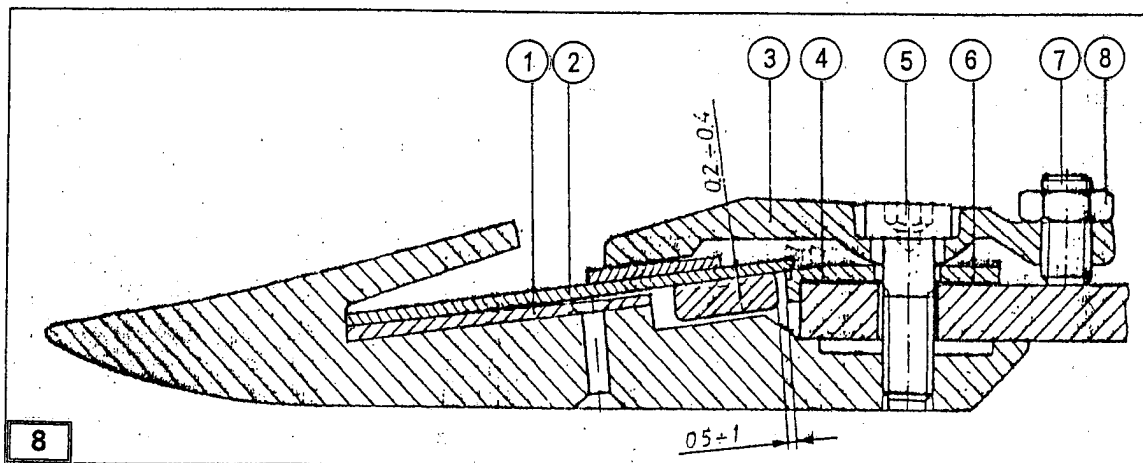

- After adjusting the gap, check that the cutting line can be started by hand. If this is not possible, re-adjust the guides. Excessively tightened guides in your work will cause overheating and rapid damage to the workpiece. Incorrectly adjusted guides do not provide proper cutting which causes mowing problems.

Sharpening and replacing the blades on the movable cutting strip

After prolonged use, the cutting edges on the knives come to grips and, therefore, the quality of the mowing decreases.

The blades are sharpened from the top and can be sharpened as long as the hardened zone on the blades lasts (see Figure 10). After sharpening, the corners on the knife must be the same as before sharpening.

If one of the pins is broken or is so blinded that it does not make sense to sharpen, it needs to be replaced. Replacing the blades is done by removing the head of the rivet from the hand grinder or file, and then it breaks out. Instead of a worn-out knife, a new one is screwed up. Correct sharpening of cutting knives is achieved by specially profiled grinding stone - wheel. For this purpose, the most suitable is tractor sharpener which provides a very simple and quick mounting on the tractor. This sharpening is also possible on the field, which is a special benefit.

The bristle is also from the production program FPM Agromehanika AD Boljevac.

After completing the work, the mower should be cleaned of the remains of the grass and any residual soil, especially in the part of the cutting machine. Lubricate all parts that can be lubricated and then put in a sheltered space. All screws and nuts should be checked frequently if they are tight and tightened if necessary.

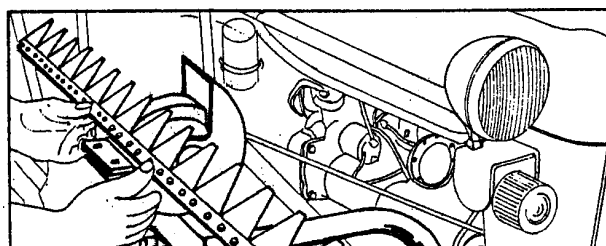

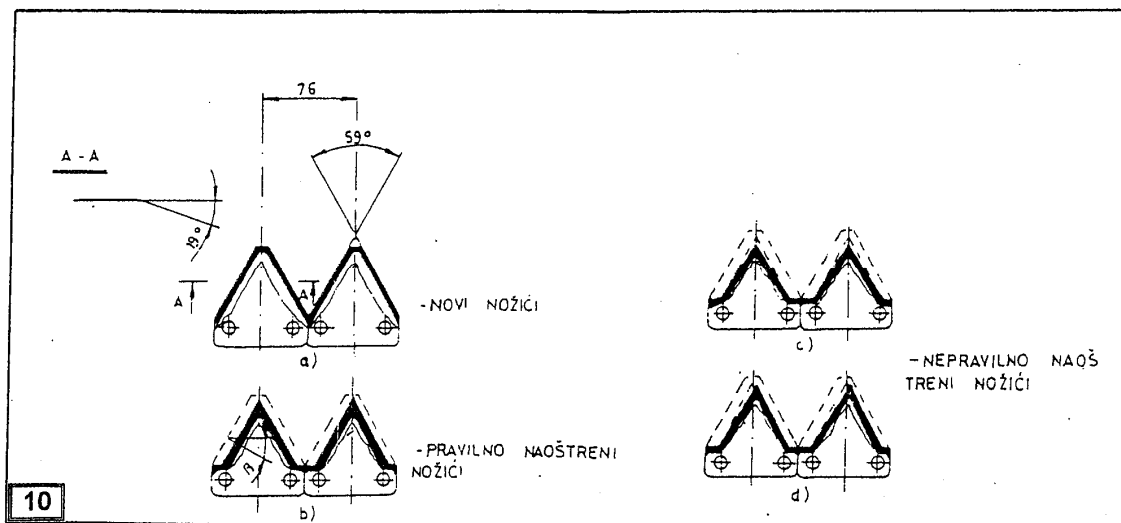

10

TECHNICAL CHARACTERISTICS

- Type and label	Rear tractor mower FPM 804 162	
- Working grasp	1.25 m	1.6 m
- Mowing speed	4 - 8 km/h	4 - 8 km/h
- The required number of turns of the output shaft of the tractor	540 min ⁻¹	540 min ⁻¹
- Number of oscillations of the cutting deck	800 - 1000 min ⁻¹	800 - 1000 min ⁻¹
- Performance	do 1 ha/h	1.25 ha/h
- Required tractor power	18 KW i više	18 KW i više
- Transport speed	20 km/h	20 km/h
- Cut height	3 - 9 cm	3 - 9 cm
- Mower mass	160 kg	170 kg

Storage of the rear tractor mower

- Storage preparations -

1. If you do not use the mower for a longer period of time, then all the parts that come in contact with the soil and the grass must be completely cleaned from the ground and grass.

2. After cleaning, wash the whole tool well.
3. Replace all damaged or broken blades or double fingers.
4. Tighten all nuts and bolts on the mower.
5. Clean rusted surfaces and bare spots and shade with protective paint.
6. Put the mower on a wooden base located under a canopy or in a separate room.



IMT FABRIKA MAŠINA I ORUĐA
"STANDARD" AD BOLJEVAC

Obrazac: 1.

Broj: 1143
11.02.1998.

U V E R E N J E

PRIMENJENE SU MERE ZAŠTITE NA RADU

Na: Zadnjoj traktorskoj kosačici

Vrsta, tip, serija i namena: Zadnja nošena: IMT 804 162 za košenje svih vrsta trava.

Godina proizvodnje: 1998. god.

Tehnički podaci:

- Radni zahvat 1,2 m, brzina kretanja u radu 4 - 8 km/h, oscilacija rezne letve 900 - 1300 min⁻¹, radni učinak 1 ha/h, a snaga traktora 18 KW i više, težina 140 daN.
- Radni zahvat 1,6 m, brzina kretanja u radu 4 - 8 km/h, oscilacija rezne letve 900 - 1300 min⁻¹, radni učinak 1,25 ha/h, a snaga traktora 18 KW i više, težina 150 daN.

Priložena dokumentacija: Uputstvo za rukovanje, održavanje i bezbedan rad, servisna knjižica i garantni list.

NAPOMENA: Oruđe za rad se ne sme koristiti van uputstva za bezbedan rad.



Ovlašćeno lice

CERTIFICATE

OCCUPATIONAL SAFETY MEASURES WERE APPLIED

On: rear tractor mower

Type, series and purpose: Tractor mower with double blades: IMT 627 089 for mowing all types of grass.

Year of manuf.: 2008

Technical data: Working grasp 2.0m, movement speed 4-8 km/h, number of cutting lath oscillations 900/1300 min⁻¹, productivity up to 1.25 ha/h, tractor power needed 18 KW and more, mass 205 kg.

Supplied documentation: Instructions for handling, maintenance and safe operation and warranty card.

NOTE: Use the rear tractor mower according to the instructions for handling and maintenance. Persons or animals must not be exposed to the area of work.

Authorised person



CAUTION:

- 1. USE A TRACTOR WITH A SAFETY CABIN TO PROTECT THE DRIVER.**
- 2. NEVER WEAR CLOTHES THAT CAN BE TRAPPED IN THE CARDAN SHAFT, OR ANY OTHER WINDING PARTS.**
- 3. DO NOT DRIVE OTHER PERSONS ON THE TRACTOR OR MOWER.**
- 4. AFTER EACH WORKING SEASON, WE RECCOMMEND THAT YOUR SERVICE FPM AGROMEHANIKA AD BOLJEVAC, CHECKS THE CONDITION OF THE MOWER, ESPECIALLY THE BLADE AND OTHER PARTS.**

5. ALWAYS COMPLY WITH THE INSTRUCTIONS IN THIS MANUAL.



CAUTION:

THIS SYMBOL IS USED IN THIS MANUAL REGARDING PERSONAL SAFETY. BE CAREFUL!



THE OPERATOR SHOULD COMPLY WITH THE SAFETY AND HEALTH PROTECTION REGULATIONS, AS WELL AS THE RULES ON ROAD TRAFFIC. IN THE OBJECTIVE OF YOUR OWN SECURITY USE THE ORIGINAL PRODUCTS PRODUCED BY FPM AGROMECHANIKA AD BOLJEVAC. THE MANUFACTURER IS NOT RESPONSIBLE FOR THE CONSEQUENCES OF INCIDENTAL USE OR NON-COMPLIANCE WITH RECOMMENDATIONS IN THIS MANUAL.

TECHNICAL PUBLICATION REALIZED BY

- Miladinović Desimir, mechanical engineer; Tabaković Smederevka.



**FOR YOUR OWN SAFETY AND TO OBTAIN THE BEST FROM YOUR MOWER, USE
ONLY ORIGINAL PARTS PRODUCED BY FPM AGROMEHANIKA AD BOLJEVAC**

FPM AGROMEHANIKA AD

19370 Boljevac, 25 Đorđa Simeonovića St.

TEL: Sales department: 030/63 455; 030/63 356

Service department: 030/63 619

Export-import department: +381 (0) 30 63 531

FAX: +381 (0) 30 63 777